

RH2-D Series

Point-of-Use Auto Pressure Regulator

Inlet Pressure	Max.2 MPaG (Max.290 PSIG)
Outlet Pressure	Max.0.99 MPaG (Max.144 PSIG) (Pressure Range: 0~0.2 MPa, 0~0.4 MPa, 0~0.6 MPa, 0~0.99 MPa)
Pressure controller	YP100
Power source	DC24 V ±10%
Power consumption	200 mA or less
External communication	4-20 mA, RS485
Pressure sensor input	4-20 mA, 1-5 V
Air supply pressure	0.4~0.6 MPa
Air supply pressure connection	0.157" (4.0 mm) Push-In Fitting

[NOTE]

1MPa = 10.2 kgf/cm² = 145.04 PSI
 1MPa = 7504.36 mmHg = 295.4 inHg



Cross sectional drawing

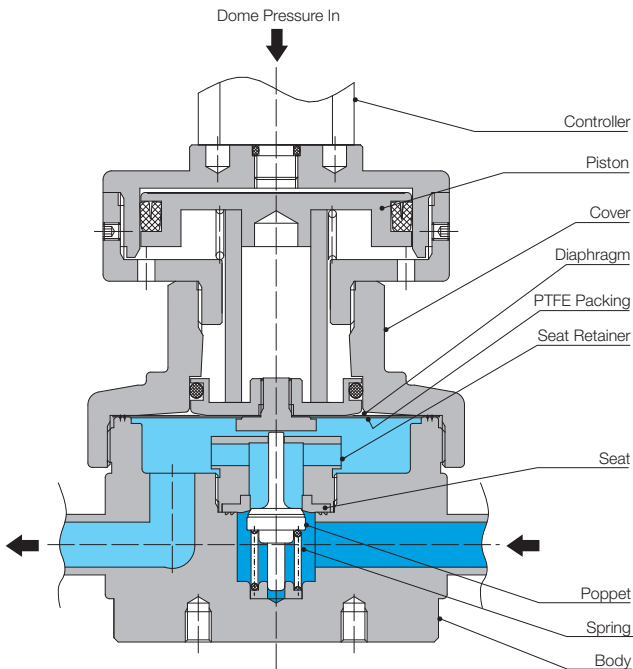

[NOTE]

- Avoid turning the control knob excessively.
- No filter in this unit.

Flow characteristics

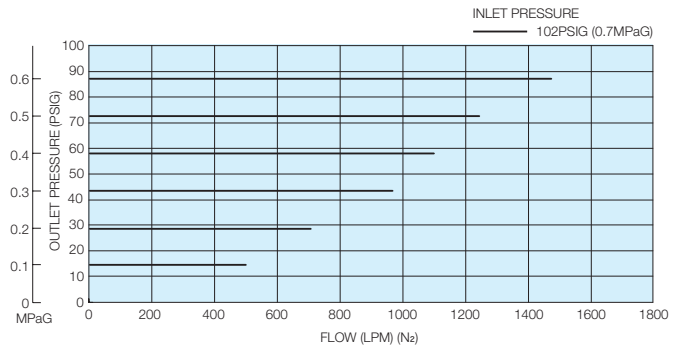

[NOTE]

- These tests were performed at ambient conditions.

Example of use

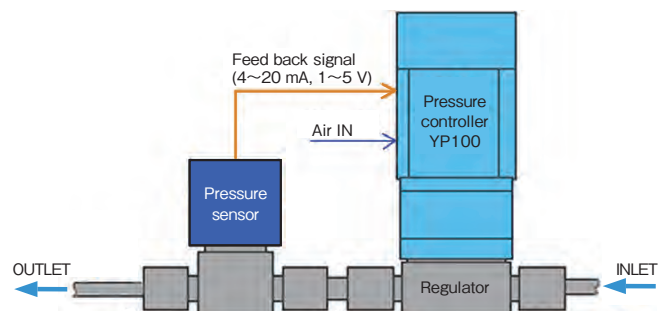

Outline drawing

Threaded holes for the rear surface installation.
2-M6X1-7.0mm (0.276in.) deep.

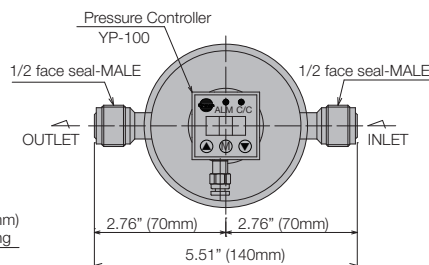
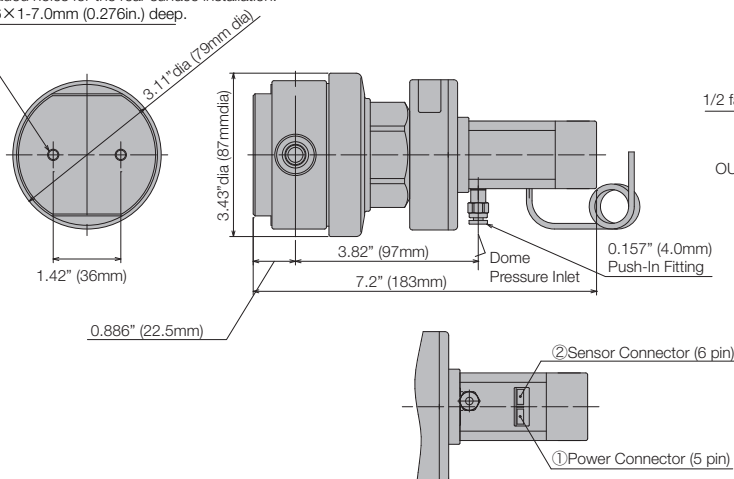

[NOTE]

- Dimensions are in inches and (mm) for reference only.
- Subject to change without notice.

Materials of construction

MODEL & TYPE	RH2SS-D
Wetted Parts	
Body	SUS316L
Poppet	SUS316L
Seat Retainer	SUS316L
Diaphragm	SUS316L
Seat	PCTFE
Spring	SUS316
Gasket to seal for gauge	Ni
Packing	PTFE
Non-wetted Parts	
Bonnet	C3604B
Pressure controller	YP100
O-ring	NBR

Wetted surface finishes

Optional Ra (GRADE "A")	7 μ m. (0.18 μ m) or less
Standard Ra (GRADE "B")	32 μ m. (0.80 μ m) or less

Standard connections

1/2" NPT body length 3.11in. (79mm)
 3/8", 1/2" face to face length of the male and female are the same. 5.51in. (140mm)
 1/2" sus tube fitting length 5.98in. (152mm)

[NOTE]

- Any combination of Face Seal male and/or female fittings are available for inlet and outlet.
- Size and configuration of pressure gauge port is 1/4" Face Seal male.

Ordering information

