

Better Pumps for Better Yields!

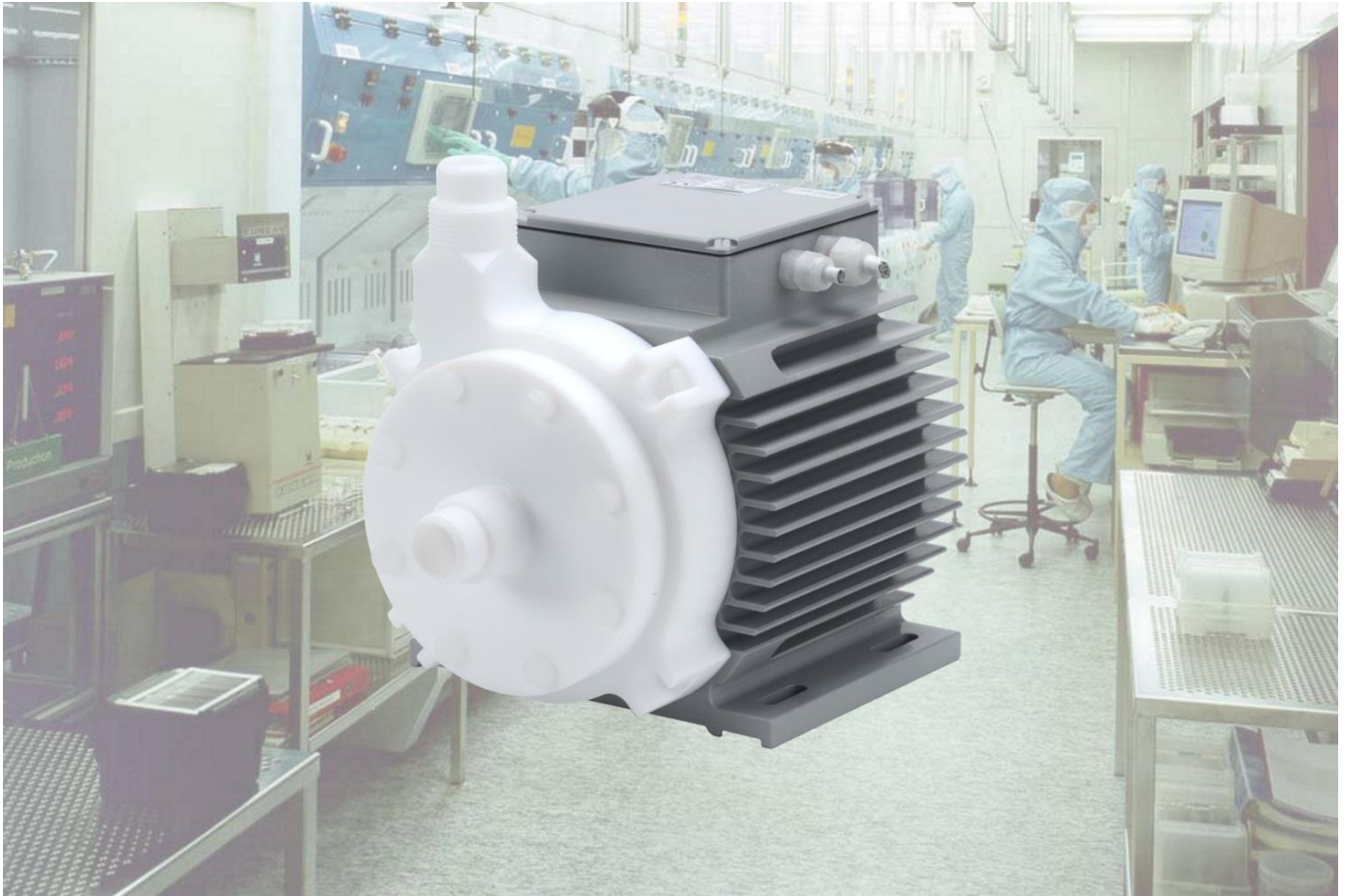

***No Seals, No Bearings,
No Particle Contamination!***

BPS-4

4.2 bar (61 psi)
140 liters/min (37 gallons/min)

***Levitronix[®] MagLev Pump Technology
Better Pumps for Better Yields!***

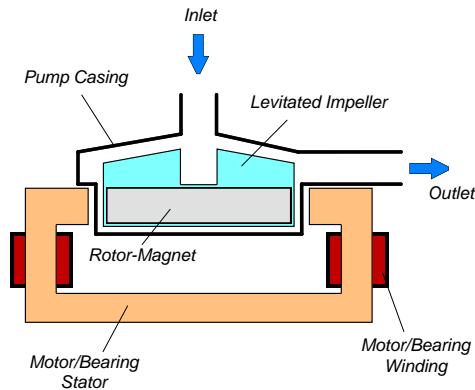

Figure 1: Schematic of the main elements of the bearingless centrifugal pump.

REVOLUTIONARY MAGNETICALLY LEVITATED CENTRIFUGAL PUMP

The BPS-4 pump system is a revolutionary centrifugal pump that has no bearings to wear out or seals to break down and fail. Based on the principles of magnetic levitation, the pump's impeller is suspended, contact-free, inside a sealed housing and is driven by the magnetic field of the motor (Figure 1). The impeller and casing are both fabricated from chemical-resistant high purity fluorocarbon resins. Together with the rotor magnet they make up the pump head. Fluid flow rate and pressure are precisely controlled by electronically regulating the impeller speed and eliminating pulsation.

SYSTEM BENEFITS

- Extremely low particle generation due to the absence of mechanically contacting parts. Reduces particle contamination issues in wet processes by generating 10 to 50 times fewer particles compared to other pumps.
- Increases equipment uptime.
- Lower maintenance costs by eliminating valves, bearings, rotating seals and costly rebuilds.
- Reduced risk of contamination due to the self-contained design with magnetic bearings.
- Very gentle to sensitive fluids due to low-shear design.
- No narrow gaps and fissures where particles or micro-organisms could be entrapped.
- Smooth, continuous flow without pressure pulsation.
- Electronic speed control.
- Compact design compared to pneumatic and magdrive pumps. Saves valuable space in process tools by having a smaller footprint.
- Proven technology in medical and semiconductor industry (MTBF > 50 years).

APPLICATIONS

- Semiconductor wet processing.
- Solar cell production.
- Flat panel display manufacturing.
- Hard-disk fabrication.
- Printer ink handling.
- Pharmaceutical production.

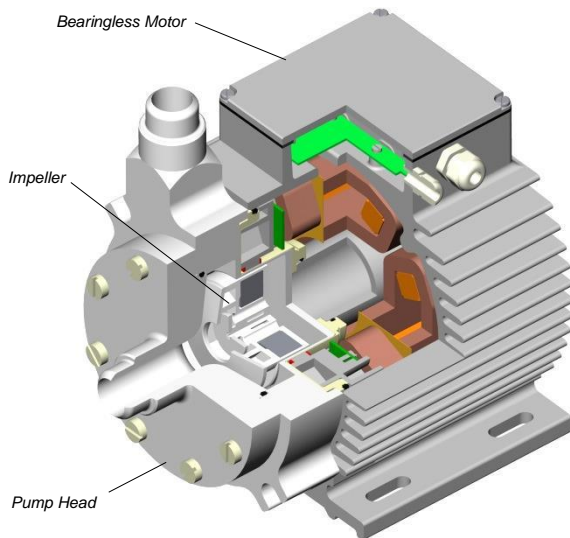

Figure 2: Cross-section of the bearingless pump motor and pump head.

SYSTEM CONFIGURATION FOR STAND-ALONE OPERATION

If the BPS-4 needs to be operated as standalone system a handheld user panel (LUI-A.1) can be attached to the RS232 port of the controller allowing the operator to set the speed manually (see Figure 5).

Furthermore the user panel displays also error messages for efficient problem solving.

SYSTEM CONFIGURATION FOR EXTENDED OPERATION

For external control with analog and digital signals a designated PLC module (PLC-A.1) can be attached to the controllers PLC interface allowing to set the speed with an analog signal and control operation with various digital signals (see Figure 6).

For more sophisticated operation and control the RS232 port on the controller can be used. Contact Levitronix® for the relevant protocol.

A computer can be connected via the RS232 interface to allow communication with Levitronix® Service Software. Hence parameterization, firmware updates and failure analysis are possible.

SYSTEM CONFIGURATION FOR PROCESS CONTROL

Precise flow or pressure control can be realized in a closed loop together with a flowmeter or pressure sensor as illustrated in Figure 7. Levitronix® provides either turnkey solutions for closed-loop flow control or helps to design your own flow control system. In addition to the flow control function, the Levitronix® control firmware comes with several condition monitoring features to monitor the integrity of the fluid circuit. Levitronix® flow control systems can generate alarms for preventive filter exchange, no-flow conditions or line clogging. Dynamic Condition Trending (DCT) enables failure prediction and scheduling of preventive maintenance.

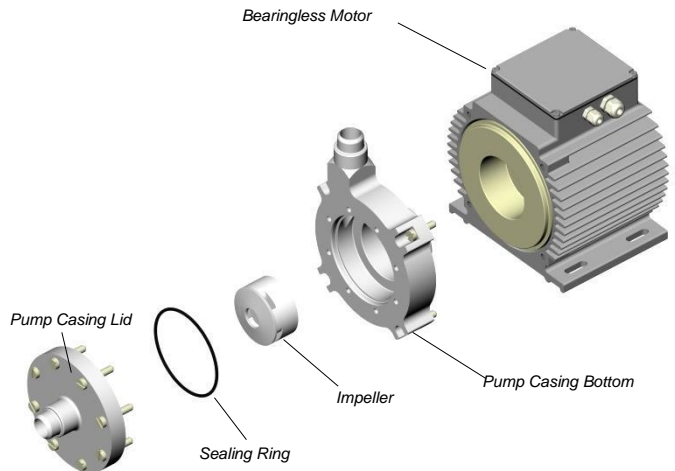

Figure 3: Disassembled pump head
(Motor BSM-4 with pump head CP-4.5)

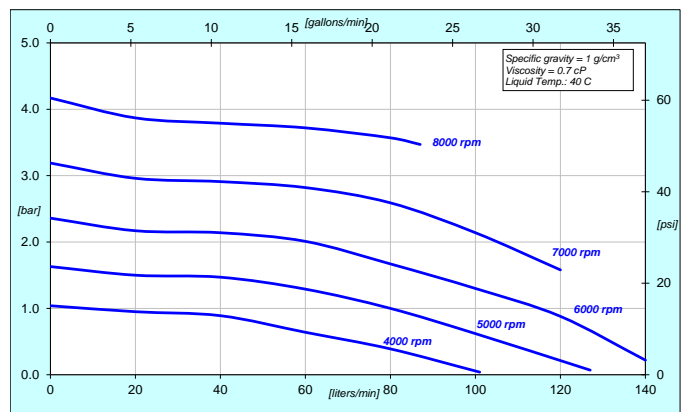

Figure 4: Pressure/flow curves
(Curves measured with pump head CP-4.5)

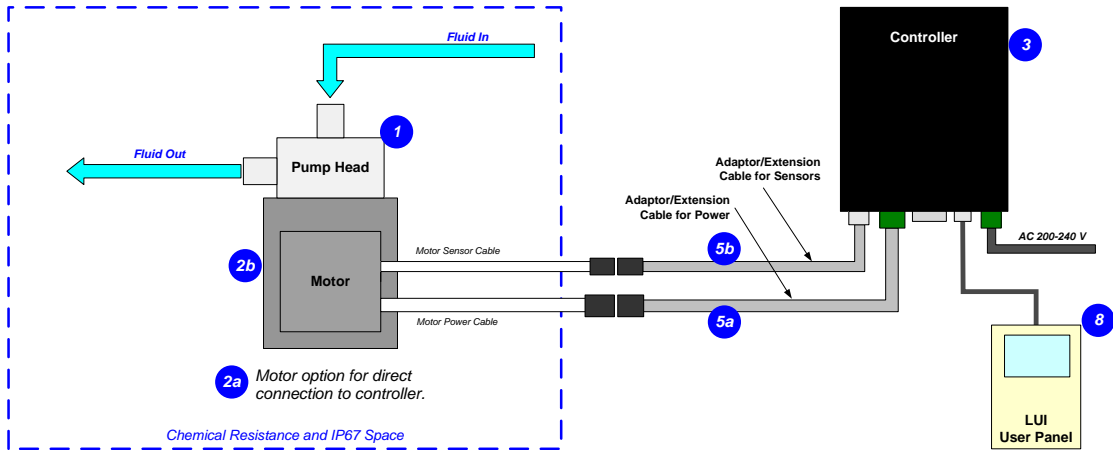

Figure 5: System configuration for standalone operation (Speed setting with user panel)

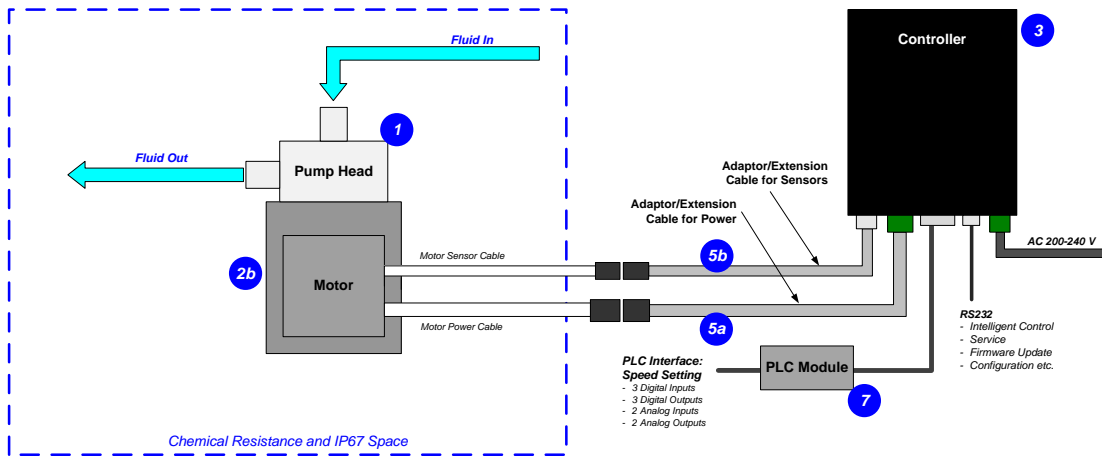

Figure 6: System configuration for extended interface operation with PLC module

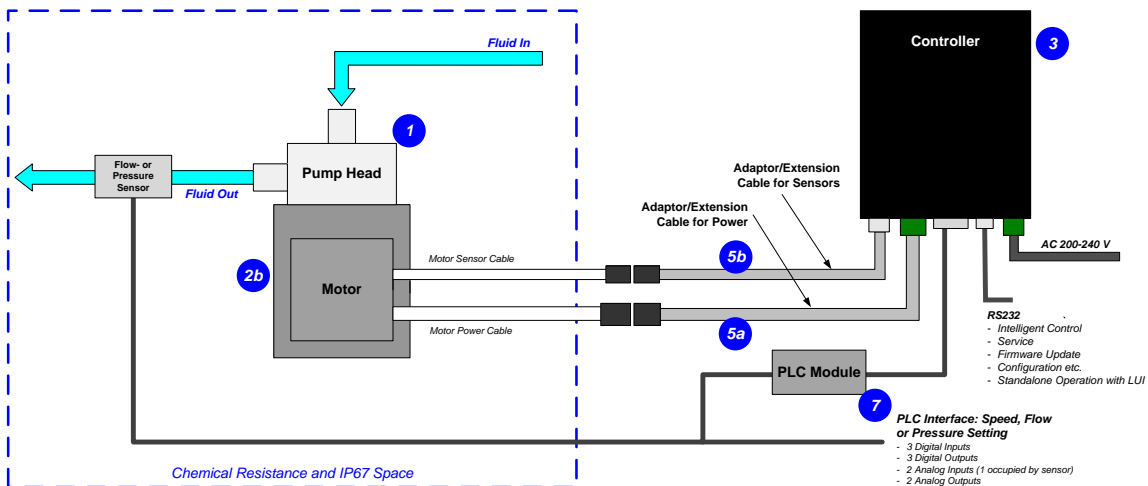

Figure 7: System configuration for process control (pressure or flow)

DIMENSIONS OF MAIN COMPONENTS

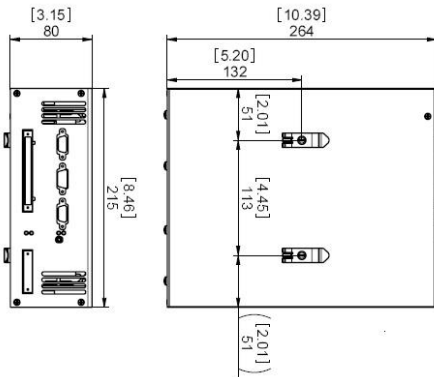

Figure 8: Dimensions of controller LC325P (same for LC325)

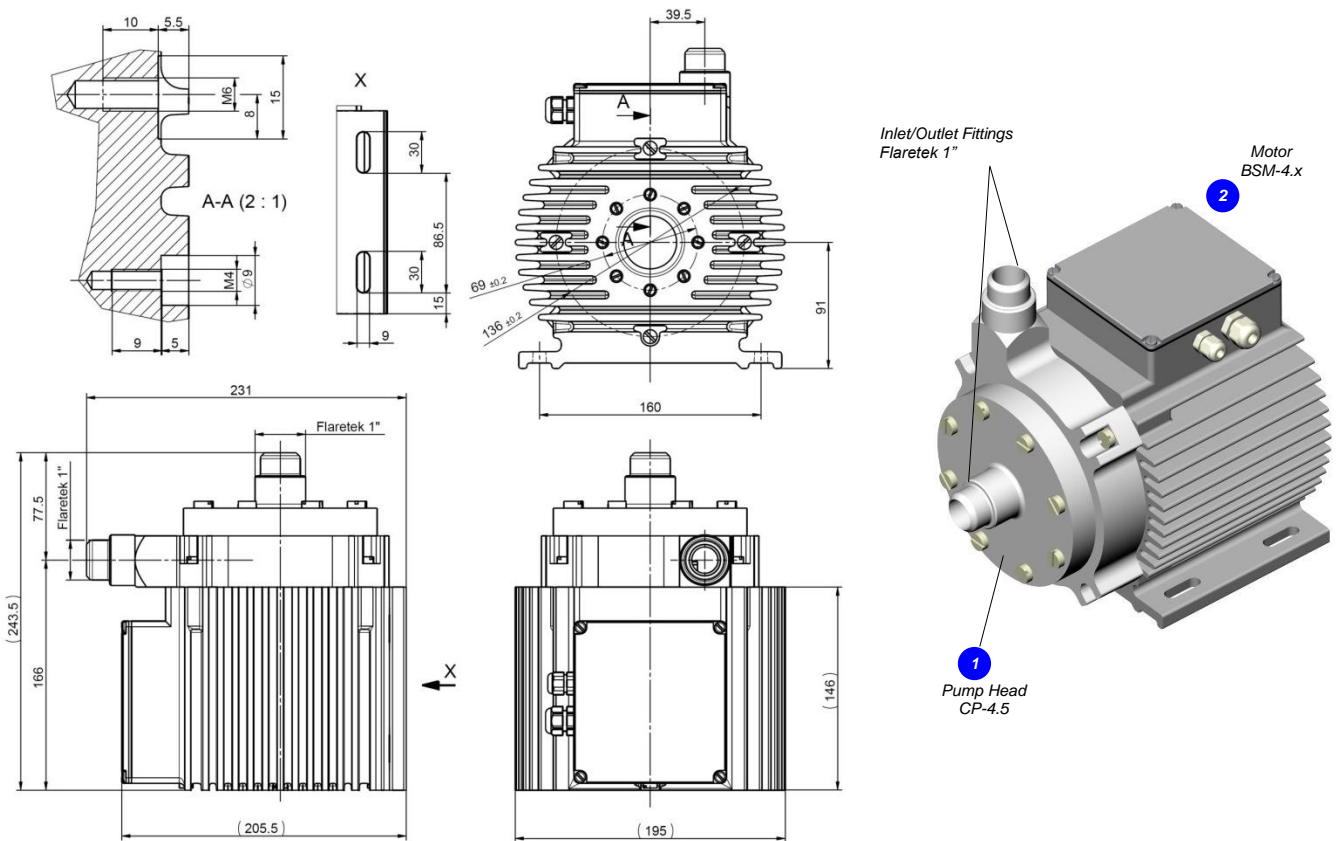

Figure 9: Dimensions of motor BSM-4.x with pump head CP-4.5
(Dimensions in [mm])

ORDER INFORMATION

System Name	Article #	Pumphead	Motor	Controller	Note
BPS-4.10	100-90146	CP-4.5	BSM-4.2-30	LC325	--
BPS-4.12	100-90165	CP-4.5	BSM-4.1	Legacy Product (see comment below)	Adaptor/Extension (0.5 - 10m) cables according to Table 3 have to be ordered as separate article with specified length.
BPS-4.10P	100-90994	CP-4.5	BSM-4.2-30	LC325P	--
BPS-4.12P	100-90995	CP-4.5	BSM-4.1	LC325P	Adaptor/Extension (0.5 - 10m) cables according to Table 3 have to be ordered as separate article with specified length.

Table 1: Standard system configurations

Pos.	Component	Article Name	Article #	Characteristics	Value / Feature
1	Pump Head	CP-4.5	100-90230	Impeller / Pump Housing Sealing Ring Fittings Inlet/Outlet	PFA / PTFE Kalrez® 1 Flaretek 1"
				Max. Flow Max. Diff.-Pressure	140 liters/min / 37 gallons/min 4.2 bar / 61 psi
2a	Motor	BSM-4.1	100-10007	Housing	- ETFE (chemical resistant) coated Aluminum - waterproofed (IP67)
				Cable / Connectors	2x 6m cables with FEP jacket for direct connection to controller.
2b	Motor	BSM-4.2-30	100-10011	Cable / Connectors	2x 3m cables with FEP jacket / 2x circular (M23, IP-67)
3a	Controller	LC325 Legacy Product: Not to be used for new applications. Replacement article is LC325P.	100-30003 (Power supply connector included in 100-90313)	Voltage / Power	3x 200 or 208 V AC, 1x 230 V AC, ± 10%, 50/60 Hz / 1500 W
				Interfaces for Standalone Controller	PLC (needs PLC module PLC-A.1) RS232 (for control, debugging with Service Software or operation with LUI-A.1)
				Standard Firmware	S1.48
3b	Controller	LC325P	100-30011 (Power supply connector included in 100-90332)	Voltage Power	3x 200 or 208 V AC, 1x 230 V AC, ± 10%, 50/60 Hz 2500 W (limited to 1500 W by firmware)

Table 2: Specification of standard components
1: Kalrez® is a registered trademark of DuPont Dow Elastomers

Pos.	Component	Sensor Cable (a)		Power Cable (b)		Characteristics	Value / Feature
		Article Name	Article #	Article Name	Article #		
4 (a+b)	Extension Adaptor Cables (FEP)	MCAS-3.2-05 (0.5m)	190-10244	MCAP-4.4-05	190-10247	Jacket Material Connectors Sensor Connectors Power	FEP Circular, Metallic (IP-67) to D-SUB Circular, Metallic (IP-67) to COMBICON
		MCAS-3.2-30 (3m)	190-10094	MCAP-4.4-30	190-10095		
		MCAS-3.2-50 (5m)	190-10026	MCAP-4.4-50	190-10096		
		MCAS-3.2-70 (7m)	190-10245	MCAP-4.4-70	190-10248		
		MCAS-3.2-100 (10m)	190-10246	MCAP-4.4-100	190-10249		
5 (a+b)	Extension Adaptor Cables (PVC)	MCAS-3.5-05 (0.5m)	190-10250	MCAP-4.5-05	190-10254	Jacket Material Connectors Sensor Connectors Power	PVC Circular, Metallic (IP-67) to D-SUB Circular, Metallic (IP-67) to COMBICON
		MCAS-3.5-30 (3m)	190-10251	MCAP-4.5-30	190-10255		
		MCAS-3.5-50 (5m)	190-10169	MCAP-4.5-50	190-10171		
		MCAS-3.5-70 (7m)	190-10252	MCAP-4.5-70	190-10256		
		MCAS-3.5-100 (10m)	190-10253	MCAP-4.5-100	190-10257		

Table 3: Specification of standard adaptor/extension cables

Pos.	Component	Article Name	Article #	Characteristics	Value / Feature
6	Impeller Exchange Kit	IEK-4.2	100-90510	Impeller (a) / O-Ring (b) Pump Casing Screws (c) Pump Motor Screws (d) Imp. Exchange Tool IET-3.1 (e)	IMP-4.2 in PFA / O-Ring, Kalrez®, 98.02 x 3.53 8pcs M8x40, PVDF 4pcs M8x30, PVDF POM-C
7	PLC Module	PLC-A.1	100-30200	Digital Inputs Digital Outputs	3x 24V DC (typical), galvanic isolated 3x closing relay (30V, 1A)
				Analog Inputs Analog Outputs	2x 4-20mA, not galvanic isolated 2x 0-5V, not galvanic isolated
8	Handheld User Interface	LUI-A.1	100-30300	Interface	RS232
9	Screw Set	Screw Set SS+PTFE	100-90950	Number/Dimensions Material	4 pcs M8x30 and 8 pcs M8x40 Stainless Steel+PTFE coating For higher pressure and hammering effect robustness.
10	Air Cooling Module	ACM-4.2	190-10139	Material / Connection Cooling Medium	PP+GF30 / NPT 1/4" Compressed air or N2

Table 4: Specification of standard accessories

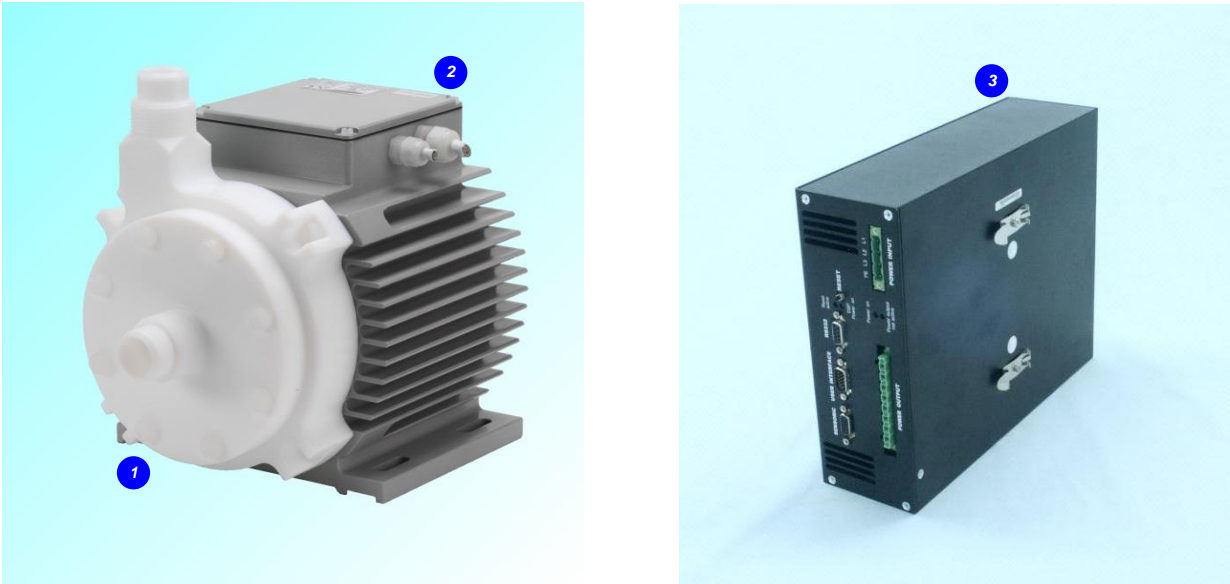

Figure 10: Pump system with standard components



Figure 11: Accessories

**Levitronix[®] MagLev Pump Technology
Better Pumps for Better Yields!**

LEVITRONIX® THE COMPANY

Levitronix® is the world-wide leader in magnetically levitated bearingless motor technology. Levitronix® was the first company to introduce bearingless motor technology to the Semiconductor, Medical and Life Science markets. The company is ISO 9001 certified. Production and quality control facilities are located in Switzerland. In addition, Levitronix® is committed to bring other highly innovative products like the LEVIFLOW® flowmeter series to the market.



Headquarter and European Contact

Levitronix GmbH
Technoparkstr. 1
CH-8005 Zurich
Switzerland

Phone: +41 44 445 19 13
Fax: +41 44 445 19 14
E-Mail: salesEurope@levitronix.com

US Contact

Levitronix Technologies LLC
20 Speen Street, Suite 102
Framingham, Massachusetts 01701
USA

Phone: +1 508 861 3800
Fax: +1 508 861 3837
E-Mail: salesUS@levitronix.com

Japan Contact

Levitronix Japan K.K.
Wing Eight 5floor, 4-16-4
Asakusabashi, Taito-ku
Tokyo, 111-0053 Japan

Phone: +81 3 5823 4193
Fax: +81 3 5823 4195
E-Mail: salesJapan@levitronix.com

Taiwan Contact

Levitronix Taiwan
5F, No. 251, Dong Sec. 1,
Guangming 6th Rd., Chu Pei City,
Hsin-Chu 302, Taiwan, R.O.C.

Phone: +886 3 657 6209
Fax: +886 988 321472
E-Mail: salesAsia@levitronix.com